

Gas-Fired Tempered Make-Up Air Unit

Model:

TK1-P1H-FF

1-Phase, 230V, 1.50 HP, Belt driven with Motorized Damper and 10" Blower. MAX 2500 CFM's





TK1-250 Direct Fired (615 lbs.)

Supply Motor:

Model 00158OT1BAO56-S40PK, 1.500 HP, 1 Phase, 230 V, 60Hz, 6.8 FLA, ODP (Open Drip Proof)

Supply Motor Pulleys:

<u>Part Type</u>	<u>Qty</u>	<u>Browning #</u>	<u>Turns Out</u>
Blower Pulley	1	AK46 x 3/4	
Motor Pulley	1	1VL40 x 5/8	2.5

Burner:

Min Output BTU: 18,000 BTU/Hr
Max Output BTU: 275,000 BTU/Hr
Size: 6" long
Gas Type: Natural

Supply Performance:

Volume: 2500 cfm Volume Range: 1000-2500 cfm
RPM: 1236
TS: 3236 ft/min
SP: 0.620" w.g.
0.500" Ext. + 0.071" Int. + 0.049" Opt.
BHP: 1.364

Heating Schedule:

Altitude: 0'
Winter Entering Air Dry Bulb Temp: 0°F
Temp Rise: 100°F
Output BTU: 270000
Input BTU: 293478
BTUs BASED OFF STANDARD AIR DENSITY

Supply Installation Information:

Gas Inlet Pressure: 7 in. w.c. - 14 in. w.c.
Insurance: No Insurance Requirement (ANSI)
Unit Main Input: 9.6 Amps MCA, 15 Amps MOP, 230 V, 14 AWG Wire Min.
Supply Unit Voltage: 1 phs 230 V 60Hz

Construction Features

Housing constructed of heavy duty G90 galvanized steel • Forward curved centrifugal blower wheel • Vibration isolation • Adjustable drive assemblies • Adjustable motor mount • Ball bearing motors • Heavy duty, pre-lubricated bearings rated for 200,000 hours of operation • Static resistant belts • Service doors on both sides • Horizontal & down discharge • Large intake area ensures low pressure drop across unit • Spring loaded profile plates automatically adjust for any airflow - no manual setting required! • Weatherproof safety disconnect switch • Modular design provides design flexibility • Fully insulated casing

Blower:

10" forward curved, centrifugal blower. Permanently lubricated ball bearings. Galvanized finish. 3/4" x 19" Shaft. 0-4000 CFM. 2500 max. RPM. Used in heated and non-heated supply fans.

Temp Control:

RTC Solutions • 40-90°F Discharge Temp Control • Field Wired On/Off Start Command

Intake:

Sloped Filtered Intake for Size #1 Modular Heater. 21.813" Wide x 44.375" Long x 23.375" High. Includes 2" MV EZ Kleen Metal Mesh Filters.

Filters:

3x MV EZ Kleen Metal Mesh Filter. 16"x 20"x 2" Used for heater and supply fan intakes. (3412)

Selected Options:

- Motorized Back Draft Damper 16" X 18" for Size 1 Standard & Modular Heater Units w/Extended Shaft, Standard Galvanized Construction, 3/4" Rear Flange, Low Leakage, TFB120S Actuator Included
- Low Fire Start. Allows the burner circuit to energize when the modulation control is in a low fire position.
- Gas Pressure Gauge, 0-35", 2.5" Diameter, 1/4" Thread Size
- Gas Pressure Gauge, -5 to +15 Inches Wc., 2.5" Diameter, 1/4" Thread Size

TK1 DIRECT FIRED HEATER

1. DIRECT GAS FIRED HEATED MAKE UP AIR UNIT WITH 10" BLOWER
2. INTAKE HOOD WITH EZ FILTERS
3. DOWN DISCHARGE - AIR FLOW RIGHT -> LEFT
4. MOTORIZED BACK DRAFT DAMPER W/ STANDARD GALVANIZED CONSTRUCTION, LOW LEAKAGE, TFB120S ACTUATOR 5. LOW FIRE START. ALLOWS THE BURNER CIRCUIT TO ENERGIZE WHEN THE MODULATION CONTROL IS IN A LOW FIRE POSITION.
6. GAS PRESSURE GAUGE, 0-35"
7. GAS PRESSURE GAUGE, -5 TO +15 INCHES WC.

NOTE: SUPPLY DUCT MUST BE INSTALLED TO MEET SMACNA STANDARDS. A MINIMUM STRAIGHT DUCT LENGTH MUST BE MAINTAINED DOWNSTREAM OF UNIT DISCHARGE UNLESS OTHERWISE SPECIFIED. DO NOT RELY ON UNIT TO SUPPORT DUCT IN ANY WAY. FAILURE TO PROPERLY SIZE DUCTWORK MAY CAUSE SYSTEM EFFECTS AND REDUCE PERFORMANCE OF THE EQUIPMENT.

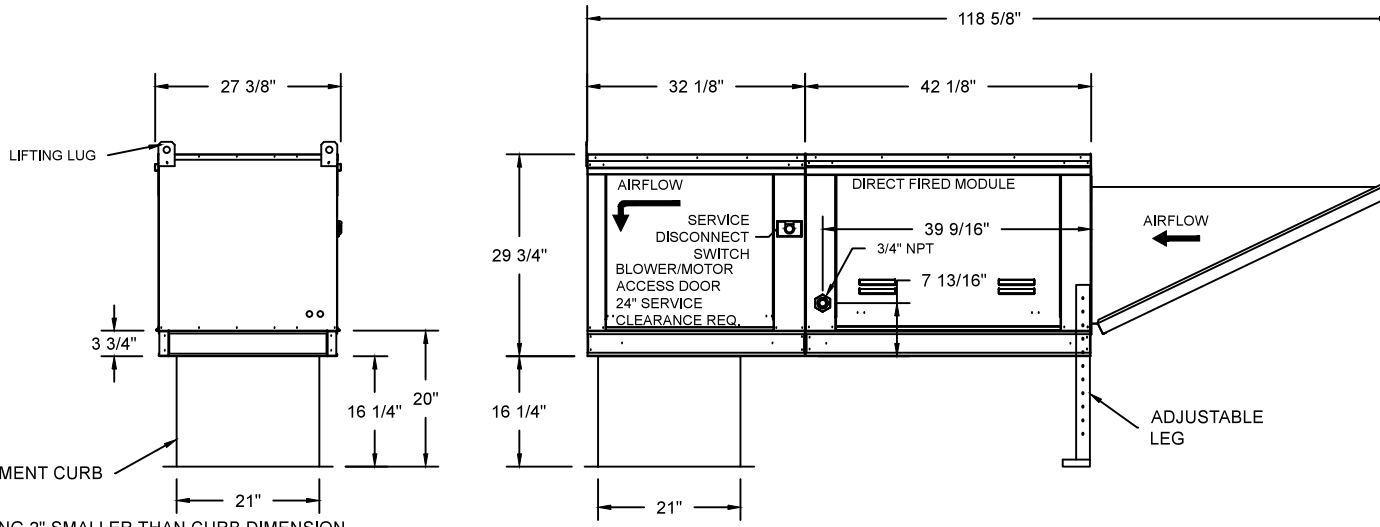
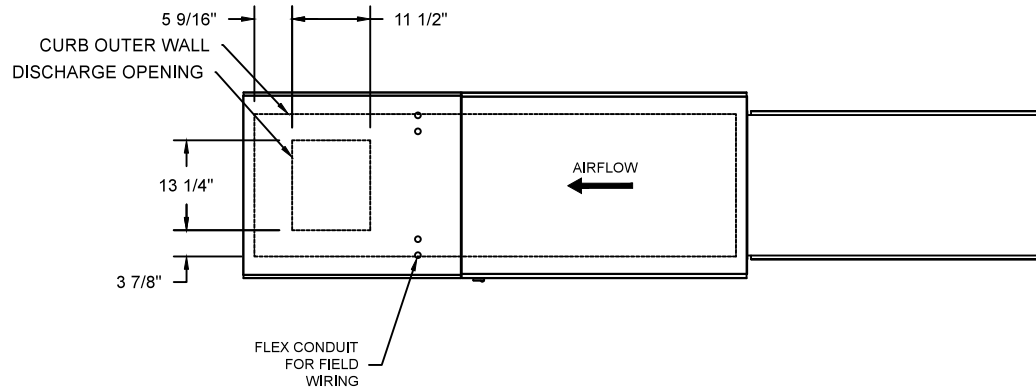

ROOF OPENING 2" SMALLER THAN CURB DIMENSION.

**NORTH AMERICAN
KITCHEN SOLUTIONS
INCORPORATED**

<i>JOB</i>	
<i>LOCATION</i>	
<i>DATE</i> 08/01/2018	<i>JOB #</i>
<i>DWG #</i> TK1	<i>DRAWN BY</i>
<i>REV.</i>	<i>SCALE</i>

(2500 1.5HP/1PH-230V) - HEATER PERFORMANCE CURVES.

2500 CFM, 0.62 SP @ 1236 RPM and 1.364 BHP at 0 feet and 100 deg F
 * Please note that these curves were adjusted for job specific temperature and altitude.

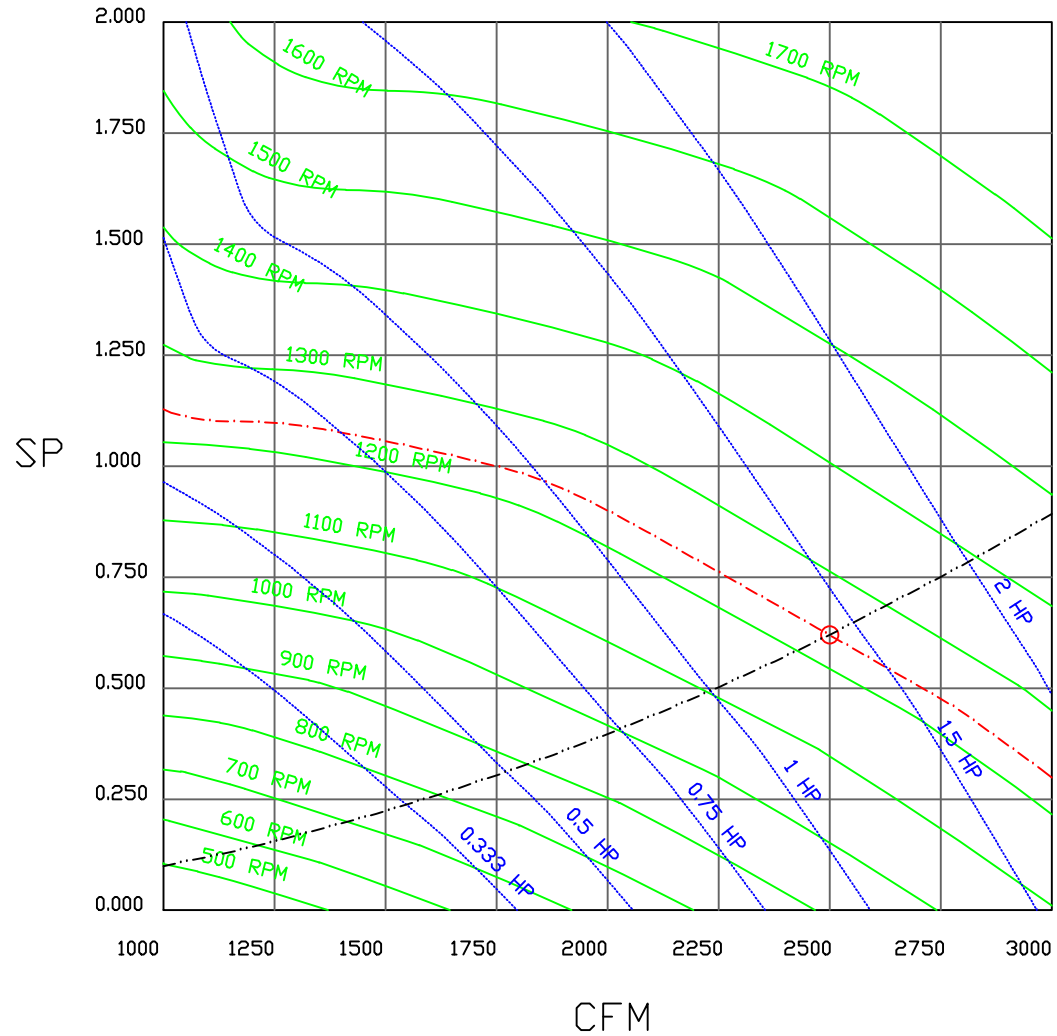

	naKS NORTH AMERICAN KITCHEN SOLUTIONS INCORPORATED		<i>JOB</i>		
			<i>LOCATION</i>		
			<i>DATE</i> 8/3/2018	<i>JOB #</i>	
			<i>DWG #</i>	<i>DRAWN BY</i>	
			<i>REV.</i>	<i>SCALE</i> 3/8" = 1'-0"	

Direct Fired Heater Wiring

JOB NAKS Direct Fired MUA

DRAWING NUMBER

SHIP DATE

MODEL TK 1-5 Series

ATTENTION ELECTRICIAN!
 DROP FOR DISCONNECT CONNECTION
 IS FACTORY SUPPLIED
 CONNECT POWER TO THE DROP

Installed Options
 Field Wired Single Switch Control
 Motorized Back Draft Damper

Discharge Temp. Control

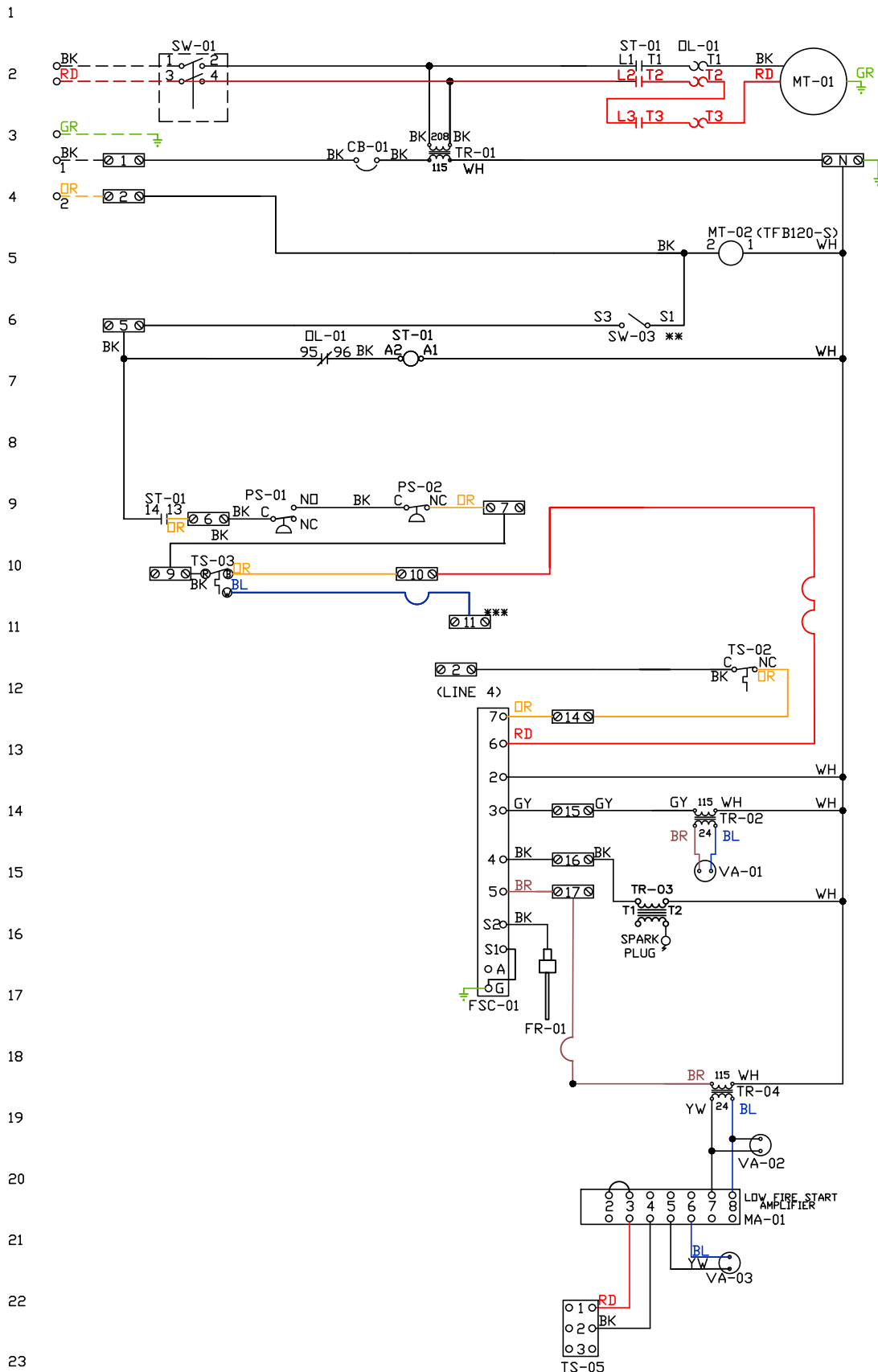

Label	Description	Location
CB-01	Circuit breaker (2amp)	[3]
FR-01	Flame rod	[16]
FSC-01	Fireeye FSC	[11-14]
MA-01	Modulating amplifier	[19]
MT-01	Supply motor	[2]
MT-02	Damper motor	[5]
DL-01	Supply motor overload	[2][7]
PS-01	Low AirFlow Switch	[9]
PS-02	High AirFlow Switch	[9]

ST-01	Supply motor contactor	[2][7][9]
SW-01	Main disconnect switch	[2]
SW-03	Damper end limit switch	[4]
TR-01	Power transformer(200v)	[3]
TR-02	Power transformer(20va)	[2]
TR-03	Ignition transformer	[14]
TR-04	Power transformer(20va)	[17]
TS-02	High temp limit switch	[10]
TS-03	Intake Air Sensor	[10]
TS-05	Discharge Air Sensor	[21]
VA-01	Pilot gas valve	[13]
VA-02	Main gas valve	[18]
VA-03	Modulating gas valve	[20]

MOTOR INFO	
SUPPLY CONTACTOR:	1.5HP-230V-1P-6.8FLA
OVERLOAD:	100-K09D10
	193-KB75

ELECTRICAL INFORMATION
 MOTOR/CTRL CIRCUIT MCA: 9.6A
 MOTOR/CTRL CIRCUIT MOP: 15A

NOTES
 --- DENOTES FIELD WIRING
 ——— DENOTES INTERNAL WIRING

** TERMINALS S4 AND S6 USED ON NF & AF SERIES ACTUATORS
 *** TERMINAL 11 PROVIDES COOLING CONNECTION

WIRE COLOR	SOCKET STYLE
BK-BLACK	ND 4 3
BL-BLUE	NC 2 1
BR - BROWN	CDL 8 7
DR - ORANGE	CDL 6 5
GY - GRAY	
GR - GREEN	
WH - WHITE	
PK - PINK	
PR - PURPLE	

Installation Wiring

JOB NAKS Direct Fired MUA

DRAWING NUMBER

SHIP DATE

MODEL TK 1-5 Series

Installed Options

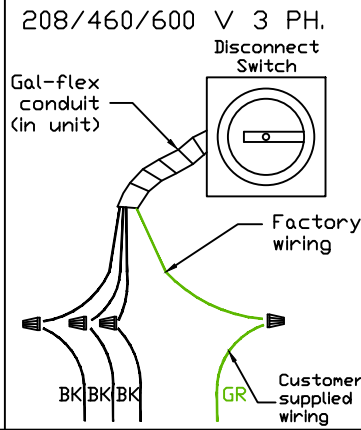
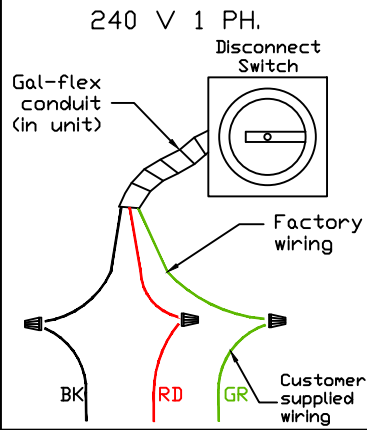
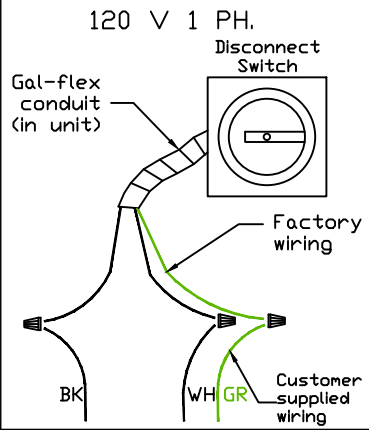

Field Wired On/Off Switch

See above details. Power Connection

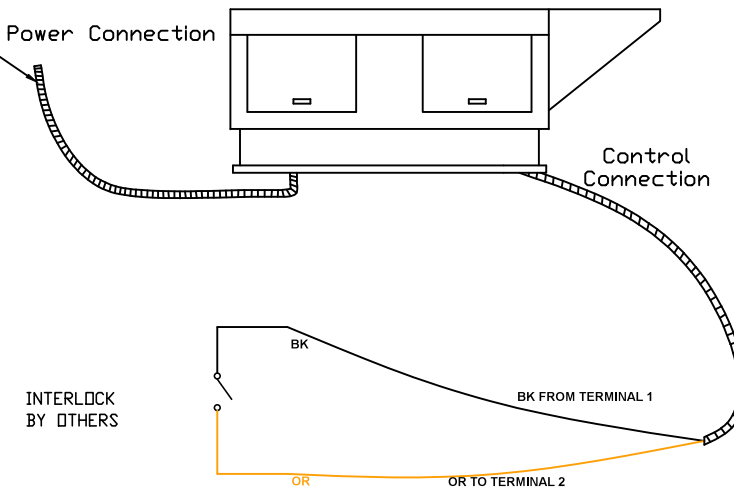

NOTES

WIRE COLOR

- | | |
|-------------|-------------|
| BK - BLACK | YW - YELLOW |
| BL - BLUE | GR - GREEN |
| BR - BROWN | GY - GRAY |
| OR - ORANGE | PR - PURPLE |
| RD - RED | PK - PINK |
| WH - WHITE | |